



QUICK RELEASE HOOK DH-QRH-HQIMDC-01



Hook Size	STATE NUMBER OF UNITS REQUIRED										
	TON	SINGLE	DOUBLE	TRIPLE	QUADRUPLE	NUMBERS	BACK TO BACK	<ex "d"> With ex "d" capstan	<ex "d"> With non ex "d" capstan	Without Capstan	Proof Load %125
25											
60											
75											
100											
125											
150											
180											

Type of Facility				
Oil <input type="checkbox"/>	Gas <input type="checkbox"/>	Product <input type="checkbox"/>	Bulk <input type="checkbox"/>	Other (Please Specify) <input type="checkbox"/>
Zoning				
Hazardous Area <input type="checkbox"/>		Non-Hazardous Area <input type="checkbox"/>		Both Hazardous & Non-Hazardous <input type="checkbox"/>
Foundation				
Concrete (Standard) <input type="checkbox"/>		Steel (Bolt Down Base) <input type="checkbox"/>		Steel (Weld Down Base) <input type="checkbox"/>
Release System				
Electrical & Manual <input type="checkbox"/>		Hydraulic <input type="checkbox"/>	Not Required <input type="checkbox"/>	Future Equipment <input type="checkbox"/>
Environmental Conditions				
Operating Temperature (°C)		Min	5	Max 60
Load Cell				
Required <input type="checkbox"/>		Not Required <input type="checkbox"/>		Future Requirement <input type="checkbox"/>
Power Supply				
Specify Voltage 3 Phase <input type="checkbox"/>		Specify Voltage Single Phase <input type="checkbox"/>		Specify Frequency Hz



QUICK RELEASE HOOK DH-QRH-HQIMDC-01





QUICK RELEASE HOOK DH-QRH-HQIMDC-01



APAK PETROKİMYA

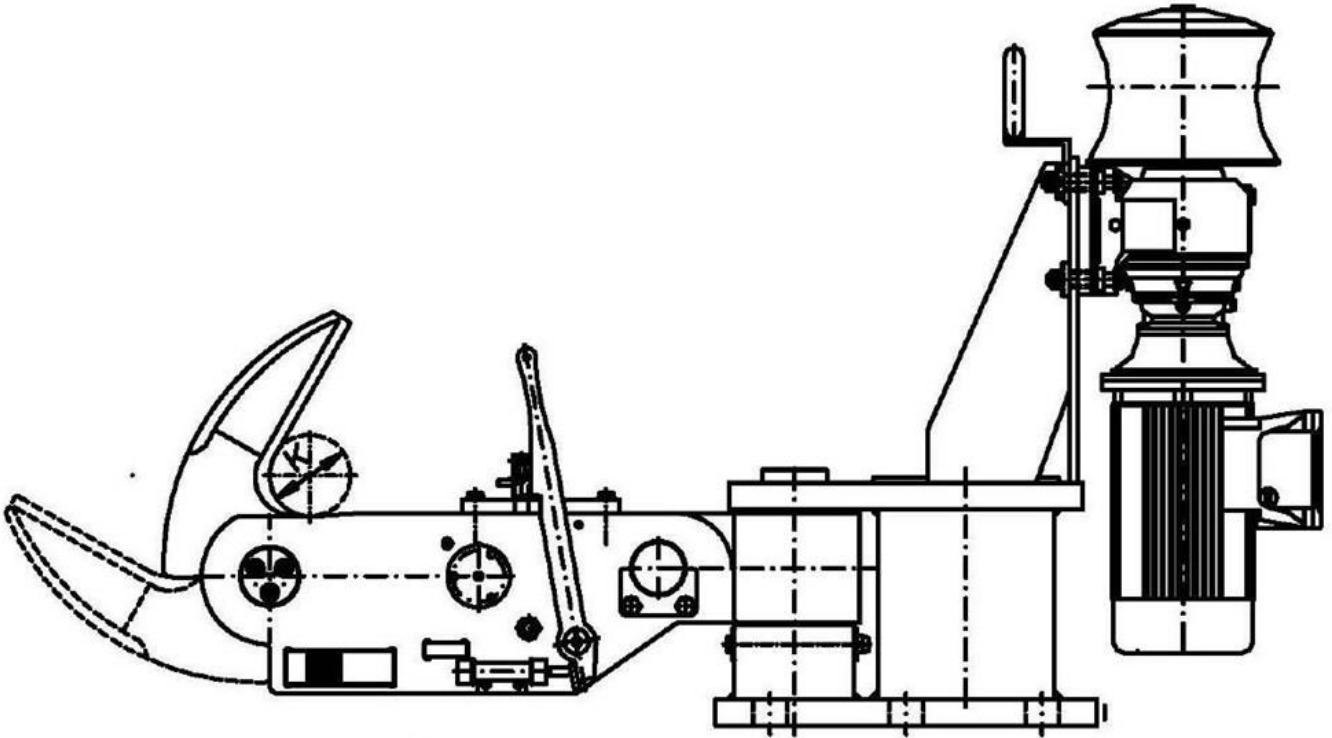
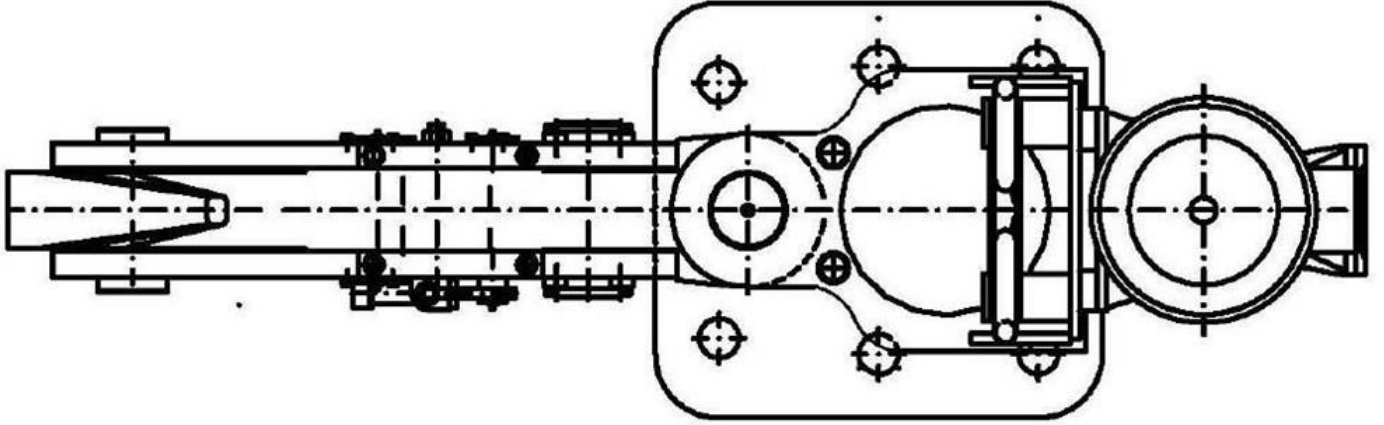



QUICK RELEASE HOOK DH-QRH-HQIMDC-01

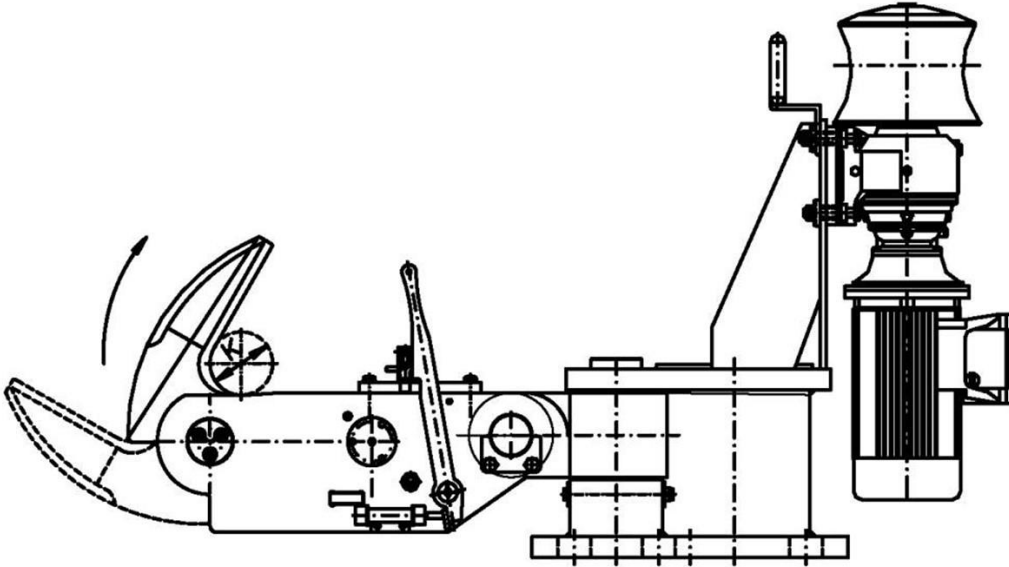
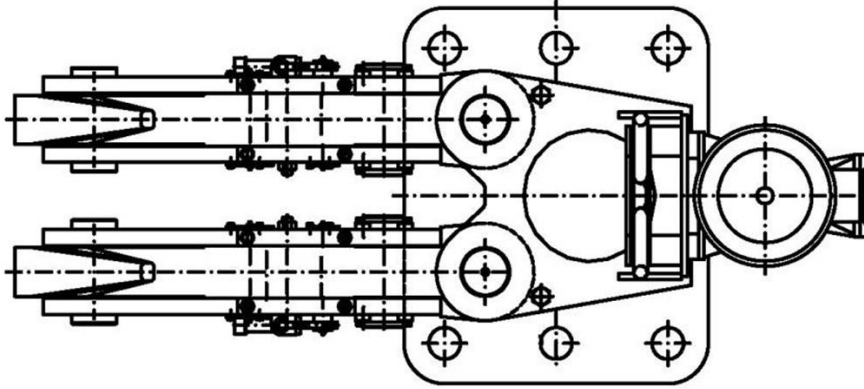



QUICK RELEASE HOOK DH-QRH-HQIMDC-01



QRH GENERAL SPECIFICATION		
1	QRH Horizontal (mounted on base) – All Series	
	Single Hook	90 to -90
	Double Hook	90 to -45
	QRH Vertical (mounted on base) – All Series	
	Single Hook	45 to -5
2	Double Hook	45 to -5
	Base Capacity, Hook Capacity	
	Single Hook	25 Ton, 25 Ton / 75 Ton, 75 Ton
	Double Hook	50 Ton, 25 Ton / 150 Ton, 75 Ton
3	Standard Hook Base Construction	ASTM A536 65-45-12
4	Temperature Range	Operating in 5 °C to 60 °C
5	Foundation Design Requirements	AS 4100-1998 suitable for concrete foundations
6	Holding Down Bolts	M--*1000mm to ISO 898-1:1999 (E) Property Class 8.8
7	Holding Down Bolts Coating	Hot Dip Galvanized to ISO 10684:2004 (E)
8	Anchor Template	Mild Steel per Base Design
9	Fasteners	Stainless Steel 316
10	Removable Release Lever	One per QRH Unit Hook
11	Hook Construction	
	Frame	Carbon Steel to ASTM A572 Grade 50
	Hook Body	High Strength Alloy Steel to ASTM A148
	Main Shafts	High Tensile Alloy Steel Grade A29 4140
12	Spark Prevention	Three polypropylene elastomeric impact blocks for energy absorption
QUALITY & TESTING		
1	NDT	ASTM E1444 – 05
2	Welding	ASTM D1.1 or AS 1554
3	Testing	125 % SWL
QRH & HOOK BASE SURFACE TREATMENT		
1	Surface Treatment	
	Surface Preparation	Class 2.5 Blast
	1 st Coat	75 micron DFT epoxy zinc-rich primer
	2 nd Coat	125 micron DFT two-part epoxy containing MIO
	3 rd Coat	75 micron re-coat able two-part polyurethane
	Color	Gloss Black
	Standard	AS1627.4
OTHER		
1	Load Cells	II 1GD Ex ia IIC T6 Ga F-IP67M Protection IP67 Marine



QUICK RELEASE HOOK DH-QRH-HQIMDC-01



CAPSTAN GENERAL SPECIFICATION		
1	Capstan Capacity	
	Starting Pull	2x Running Pull
	Note	Refer to Mooring Drawings for Dimensions, Layout and Bolts
2	Capstan Type	Reversible with Brake
3	Line Speed	30 meters / min
Minimum Environmental Protection		
4	Capstan Motor & Motor Starter	IP56 minimum
	Footswitch	IP67
Brake Details		
5	Type	Automatic, Spring applied break when de-energized
	Holding Torque	150 % of Motor Torque
6	Fasteners	Stainless Steel 316
CAPSTAN MOTOR ELECTRICAL SPECIFICATIONS		
Ex db IIB T4 Gb 7.5 Kw for capstan motor IP56 Minimum		
Ex db IIB T4 Gb 0.37 Kw for release motor IP56 Minimum		
1	Motor Control	Direct On Line (DOL) Motor Starter
2	Motor Starter Housing	Marine Grade Aluminum, Painted for Hazardous Areas
3	Capstan Electrical Controls	
	Selector Switch	Counter Clockwise / Off / Clockwise
	Emergency Stop	Push to Set, Twist to Reset
	Footswitch	Depress to Operate
4	Footswitch	
	II 2G Ex de IIC T6 Gb	
	Type	IP67 Industrial Footswitch with Foot Guard
	Construction	Marine Grade Aluminum, Hazardous Areas Intrinsically Safe
5	Space Heater	Single Phase
6	Motor Protection	Electric Overload (Thermal Trip and Phase Failure Protection), (Automatic Reset)
7	Motor Type / Insulation	Four-Pole Insulation Class F
8	Motor Electrical Parameters	3 Phase – 400 VAC +/- 10 % with Neutral @ 50Hz +/- 5%
9	Incoming 3 Phase Connections	
	Metric	32mm Entry
	QRH Power Cable Size	PVC / SWA / XLPE / CU25*4
10	Surface Treatment	As of QRH Surface Treatment